

ORIGINAL INSTRUCTIONS

# OPERATING & MAINTENANCE MANUAL



## SPACE HEATERS

# IP55

***Diesel Indirect Fired Space Heater  
Not for domestic use - Space Heating Only***

**Made in Italy for:**

Spitwater Australia Pty Ltd T/A Ottico Equipment  
953 Metry Street, Albury NSW 2640 Australia  
spitwater.com.au



CREATORS OF

**SPITWATER**



**WARNING:** Read and understand this instruction manual before operating this unit and retain for future reference. Failure to follow operating, safety and maintenance instructions outlined in this manual releases the manufacturer from any responsibility for any accidents or damage incurred and may render any warranty void.

## INTRODUCTION

Spitwater Australia is proudly Australian owned and operated since 1982. Our promise is to provide our customers with superior quality portable industrial heaters built to the highest of standards that will see many years of reliable service.

The JETFIRE range of portable industrial heaters are designed to give safe, efficient and reliable service when the correct operating and safety instructions are followed, and proper attention is given to all required maintenance procedures in order to maintain the unit in peak operating condition.

This manual provides the up to date information necessary for the user to operate the unit and carry out regular inspection and maintenance.

Please note that the information given within this manual may be subject to revision in compliance with Spitwater Australia's policy of continual improvement.

The JETFIRE range of heaters should only be used in the manner and purpose for which they were intended and in accordance with the recommendations and safety precautions detailed in this manual and in operating instructions and stickers on the unit itself.

All JETFIRE heaters undergo rigorous safety and operational tests before being dispatched into the marketplace however it is still imperative that prior to used, all operators have read and understood all information and instructions provided and are aware of possible hazards.

## GENERAL DESCRIPTION & INTENDED USE

JETFIRE Heaters are specifically designed to solve all problems relating to heating drying and desiccating in commercial and industrial applications. Some examples of applications are in warehouse and factory heating, animal husbandry and greenhouse applications.

## GENERAL DESCRIPTION & INTENDED USE

Spitwater has an extensive range of spare parts and accessories to suit all your heating needs. For spare parts, accessories and service please contact **1800 SPITWATER (1800 774 892)** and to view Spitwater's extensive range of JETFIRE industrial heaters online visit [www.spitwater.com.au](http://www.spitwater.com.au)

TECHNICAL SPECIFICATIONS			IP55
Combustion			Indirect
Max heating output	Hi	[kW]	55.0
		[kcal/h]	47.318
	Hs	[kW]	58.6
		[BTU/h]	200.728
Net heating output	Hi	[kW]	49.2
		[kcal/h]	42.350
	Hs	[kW]	52.5
		[BTU/h]	179.652
Air output		[m <sup>3</sup> /h]	2.500
Fuel consumption		[kg/h]	4.64
Power supply	Phase		1
	Voltage	[V]	230
	Plug	[A]	10
	Frequency	[Hz]	50
Power consumption		[W]	850
Nozzle		[USgal/h]	1.10-80° W
Pump pressure		[bar]	12
Flue diameter		[mm]	150
Tank capacity		[l]	65
Noise level at 1 m		[dBA]	72
Dimensions, L x W x H		[mm]	1435 x 555 x 940
Weight		[kg]	81
Fuse		[A]	10
Ajustement of combustion air flap		[mm]	a = 6
		[N°]	A = 4

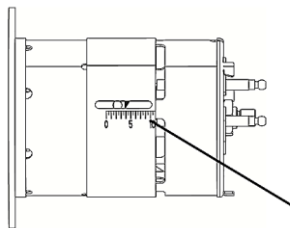

**A**

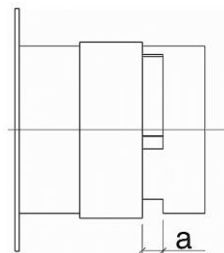

## OPERATING DIAGRAM

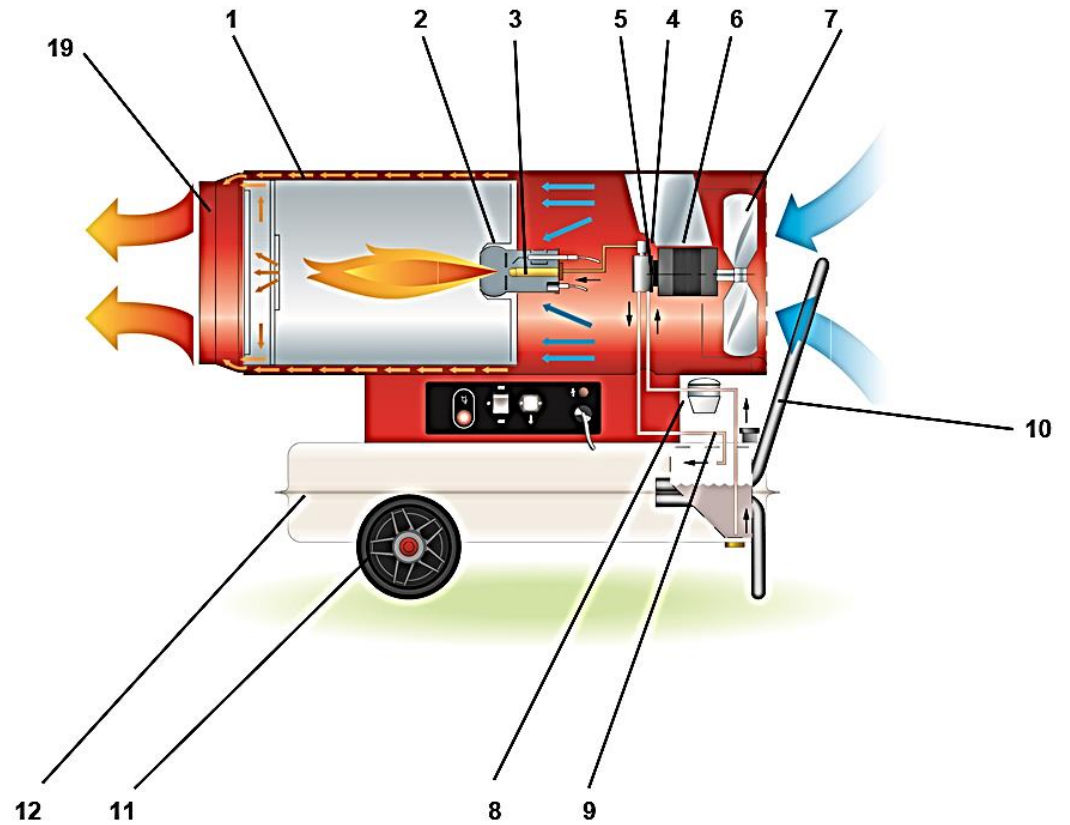
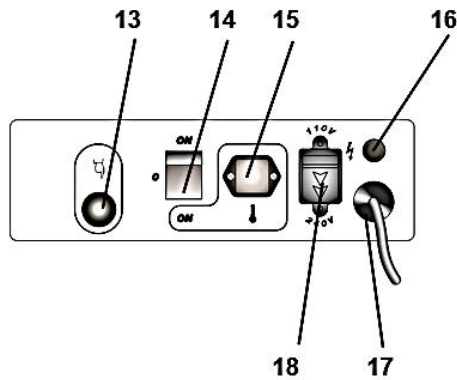
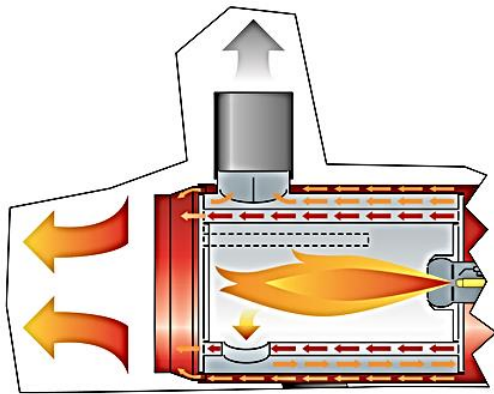

**Fig . 1**

- |                      |                   |   |                         |
|----------------------|-------------------|---|-------------------------|
| 1 COMBUSTION CHAMBER | 6 MOTOR           | 11 WHEEL                                    | 16 CONTROL LAMP         |
| 2 BURNER             | 7 FAN             | 12 FUEL TANK                                | 17 POWER CORD           |
| 3 NOZZLE             | 8 FUEL FILTER     | 13 RESET BUTTON OF THE ELECTRONIC EQUIPMENT | 18 INPUT VOLTAGE SWITCH |
| 4 SOLENOID VALVE     | 9 FUEL CIRCUIT    | 14 MAIN SWITCH                              | 19 OUTLET CONE          |
| 5 DIESEL PUMP        | 10 SUPPORT/HANDLE | 15 ROOM THERMOSTAT PLUG                     |                         |

**IMPORTANT**

Before using the space heater, carefully read all of the instructions and follow them scrupulously.

The manufacturer cannot be held responsible for damage to persons and/or property caused by improper use of the equipment.

This instruction manual is an integral part of the equipment and must therefore be stored carefully and passed on with the unit in the event of a change of ownership.

**GENERAL RECOMMENDATIONS**

The space heaters run on diesel fuel. Direct combustion versions send hot air and combustion products into the room, while indirect combustion versions are fitted with a flue to discharge the fumes through the chimney.

**Warning**

**THIS HEATER IS FOR PROFESSIONAL USE. IT HAS BEEN CAREFULLY DESIGNED FOR MOBILE AND TEMPORARY PROFESSIONAL APPLICATIONS. IT HAS NOT BEEN DESIGNED FOR DOMESTIC USE NOR FOR COMFORT HEATING AND SHOULD NEVER BE USED TO HEAT CLOSED ROOMS WITHOUT ADEQUATE VENTILATION.**

Always follow local regulations and codes when using this heater:

- Follow the instructions in this booklet very carefully;
- Use only in places free of flammable vapours or high dust content;
- Keep inflammable material at a safe distance from the heater (minimum 3 metres);
- Make sure firefighting equipment is readily available;
- Ensure that the machine resting surface or ground is not made of flammable material;
- Make sure sufficient fresh outside air is provided according to the heater requirements. Direct combustion heaters should only be used in well vented areas in order to avoid carbon monoxide poisoning;
- The indirect combustion heater is installed near a chimney to take away the fumes (see the paragraph "FUMES FLUE POSITIONING

DIAGRAM") and connected to an electrical switchboard;

- Make sure nothing is obstructing the aspiration and expulsion of air; movement of air may be obstructed in various ways including placing covers or other objects on the heater or positioning the heater too near a wall or other large object.
- In case of very low temperatures add kerosene to the heating oil.
- Make sure heater is always under surveillance and keep children and animals away from it.
- Before starting the heater always check free rotation of the fan.
- Unplug heater when not in use.

**SAFETY DEVICES**

The heater is fitted with an electronic device that controls the flame and the maximum safe temperature by means of a photocell and an overheat thermostat.

The electronic device controls start/stop times and trips the safety in case of malfunction. It has a reset button (13) that can assume different colours (Function Light) depending on the function mode:

- off: heater is in idle mode or in "stand-by" mode, waiting for heating request;
- Steady green: heater functioning normally;
- Steady red: heater in safety stop;
- Flashing orange: heating interrupted due to excessive variations in voltage supply ( $T < 175V$  or  $T > 265V$ ); heating will resume automatically when voltage returns in range from 190 V and 250 V.

**Warning**

**To restart heating after a safety stop, push reset button (13) for 3 seconds.**

## Warning



**NEVER do more than two restarts in a row: uncombusted diesel fuel may accumulate in the combustion chamber and suddenly flare up at the next restart.**

If the safety stop persists, you have to find and eliminate the cause of the stop before you restart the heater. Push button (13) for at least 5 seconds to launch a self-diagnosis programme, after which the button will assume different colours (Self-diagnosis light) depending on the type of safety that tripped:

- Flashing orange: false flame detected during restart cycle.
- Flashing red: no flame during restart cycle.
- Flashing red/green: no flame during work cycle.
- Steady orange: internal error of electronic device.

## Warning



**See “TROUBLESHOOTING” to identify the cause of the malfunction.**

## OPERATION

Before switching on the heater and, therefore, before plugging it into the electrical power supply, check that the power supply specifications are the same as those stated on the identification plate.

## Warning



- **The power line must be earthed and fitted with a residual current circuit breaker.**
- **The heater plug must be inserted into a socket equipped with a mains switch.**

The heater must be placed on a flat, stable, and levelled surface in order to prevent it from overturning and/or diesel leaks from the tank filler cap.

You can run the generator in manual by setting switch (14) to ON.

The generator can only work automatically when a control device, such as, for example, a

thermostat or a timer, is connected to the heater.

Connection to the heater is made by removing the socket cover (15) and inserting the thermostat plug.

To start the machine you must:

- If connected to the thermostat, turn the switch to (ON + ↓);
- If not connected to the thermostat, turn the switch to (ON);

## Warning



**At the end of the start cycle, the electronic control device causes button (13) to flash briefly to confirm completion of the heater start cycle.**

When unit is started for the first time or is started after the oil tank has been totally emptied, the diesel flow to the burner may be impaired by air in the circuit. In this case the control box will cut out the heater and it might be necessary to renew the starting procedure once by depressing the reset button (13).

If the heater does not function, the first things to do are:

1. Check that the tank still contains some diesel;
2. Push reset button (13);
3. If the heater still does not function, see “TROUBLESHOOTING” to identify the cause of the malfunction.

## Warning



**Never stop the machine by unplugging the electrical plug: this could cause overheating.**

## STOPPING THE HEATER

Set main switch (14) on “0” position or turn thermostat or other control device on lowest setting.

The flame goes out and the fan continues to work for approximately 90 sec. cooling the combustion chamber.

## TRANSPORT

### Warning



Before moving the heater:

- Stop the heater as indicated in the “STOP” paragraph;
- Cut electrical power by removing the plug from the electrical socket;
- Wait until the heater cools.

Before moving the heater, make sure the oil tank cap is securely attached.

### Warning



Diesel may leak during handling and transport: the fuel tank cap is not sealed. This allows air to enter and allows the tank to be emptied while the heater is running.

## MAINTENANCE

### Warning



Before starting any maintenance procedure, ALWAYS:

- Stop the heater as indicated in the “STOP” paragraph;
- Disconnect electrical power by removing the plug from the electrical socket;
- Wait until the heater cools.

Periodic maintenance of the heater is necessary to ensure proper performance and to prevent failures. To ensure correct heater function, the combustion chamber, burner, and fan must be cleaned at regular intervals by a qualified service technician. Maintenance should be performed at the following periodic intervals:

### Daily maintenance (customer to perform)

- Inspect air inlet / air outlet and exhaust stack, remove debris if any
- If any air duct is installed, secure it is fixed. Minimize bends and keep ducts straight.

- Verify fuel tank is full
- Verify that exhaust stack is properly installed

### Weekly maintenance (customer to perform)

- Disassemble, inspect and clean fuel filter with clean fuel

### Every 50 hours maintenance (qualified Spitwater service technician to carry out)

- Remove top cover and clean the motor, fan blade and the interior shell
- Inspect the fuel hose assembly and check for any leaks

### Every six months maintenance (qualified Spitwater service technician to carry out)

- Disassemble burner head
    - Inspect and clean burner diffuser
    - Inspect and replace nozzle if necessary
    - Clean ignition electrodes and adjust settings
    - Check air combustion setting
  - Check overheat thermostat
  - Inspect and clean the combustion chamber
  - Open electric board, inspect electrical components and check connections
  - Check fuel pressure setting of fuel pump
- Inspect and test the burner

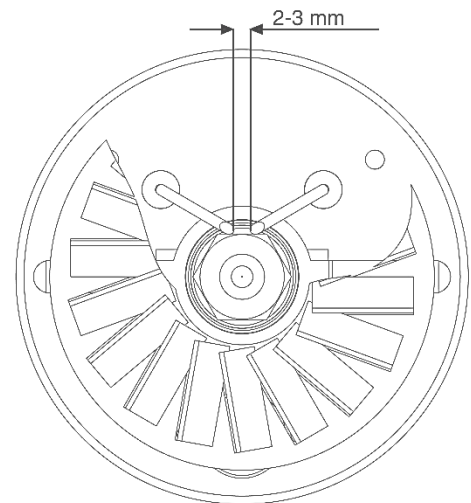



ASSEMBLY INSTRUCTIONS

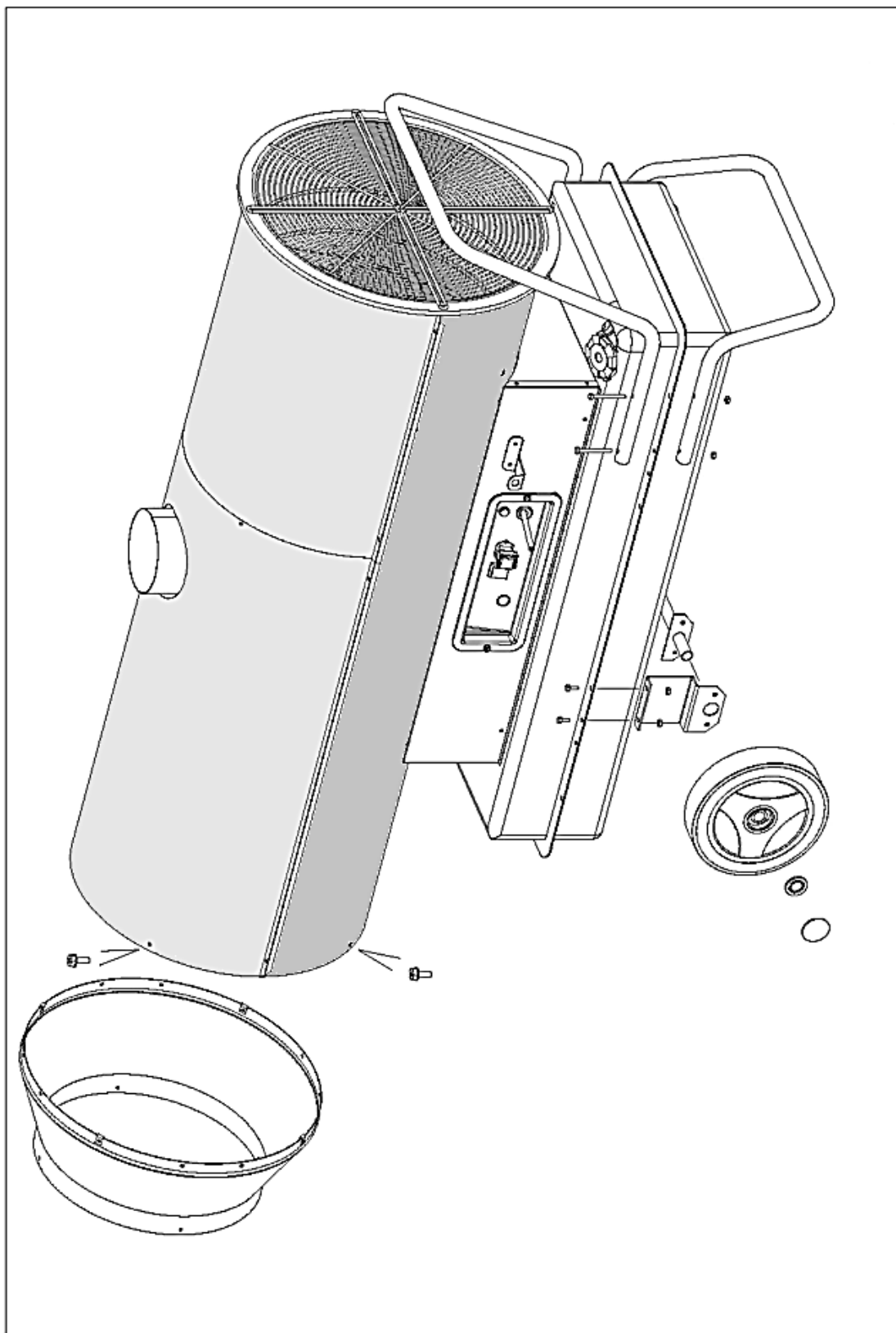



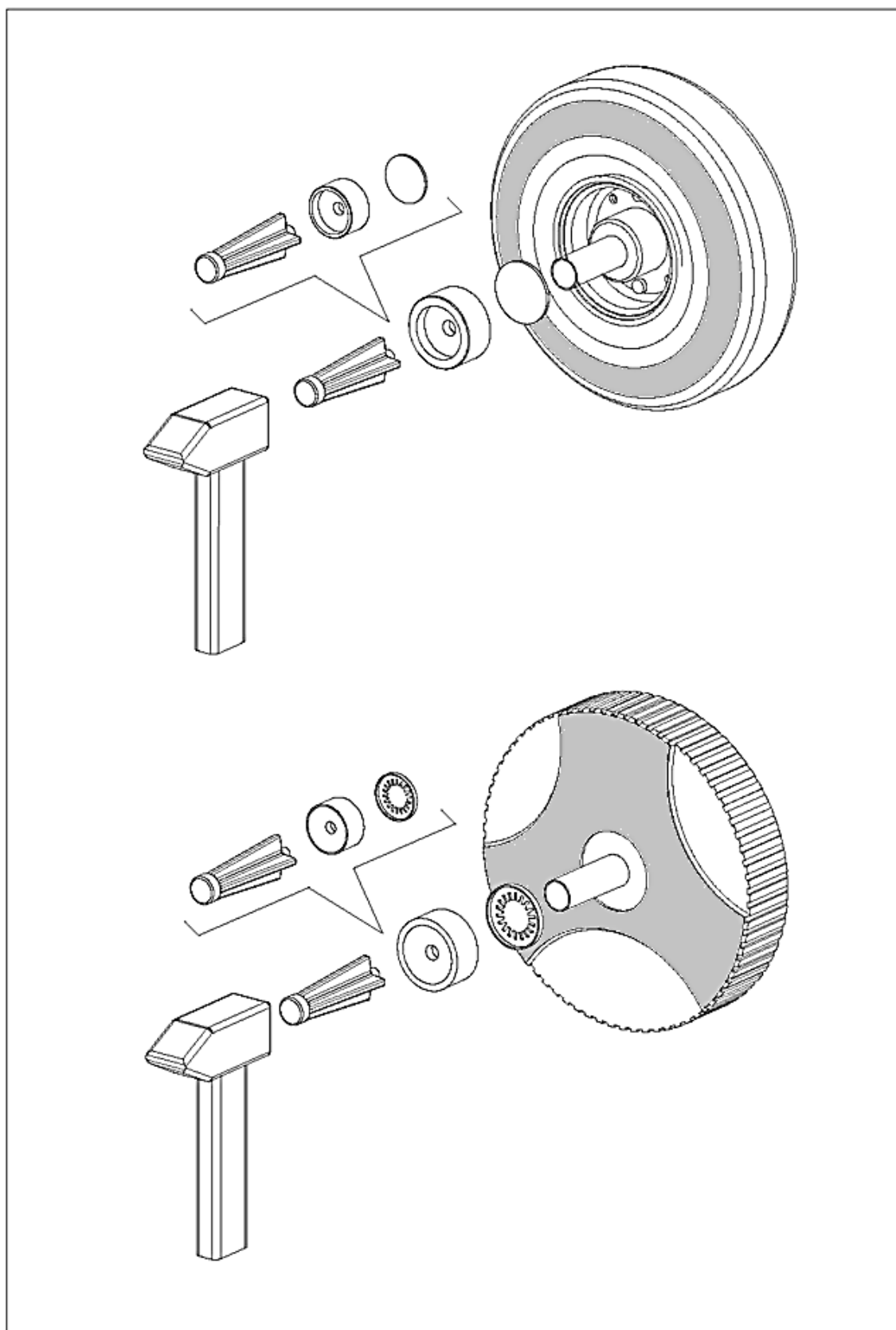

## INSTALLATION GUIDE

### RECOMMENDED CHIMNEY LAY-OUT

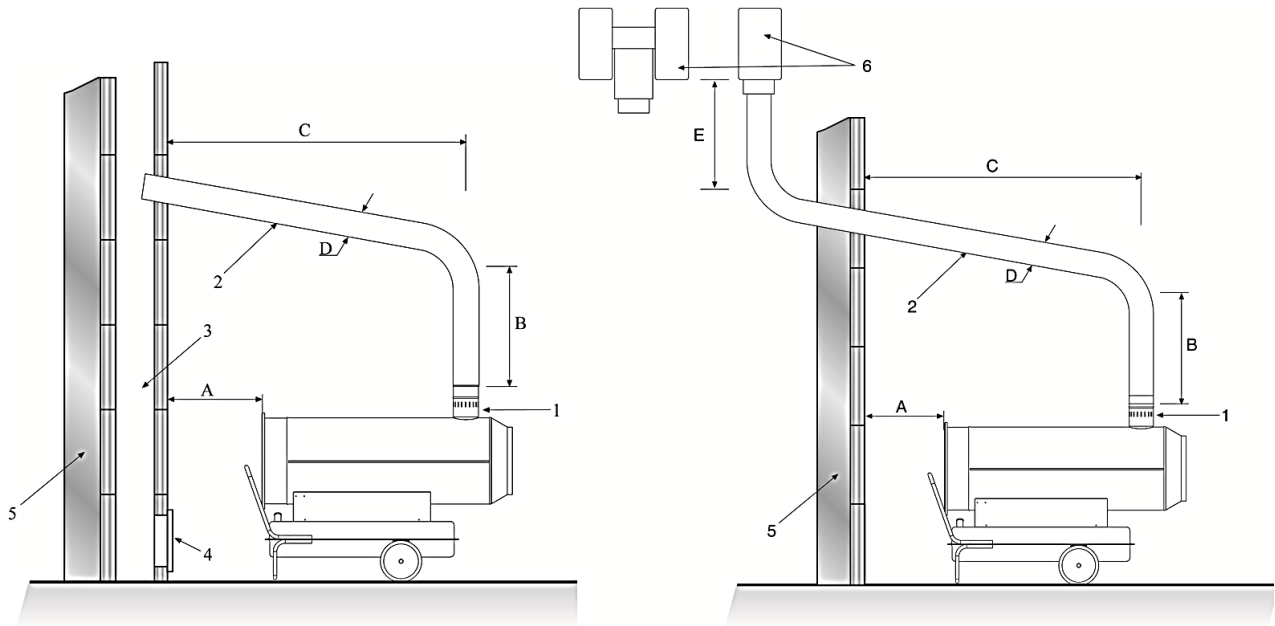

### DESCRIPTION

- A) Minimum 1 m
- B) Minimum 1 m
- C) As short as possible
- D) Greater than or equal to diameter of heater smoke outlet
- E) Minimum 1 m

- 1) Anti-wind device provided with heater
- 2) Horizontal crossing with 5° minimum upward slope
- 3) Chimney with minimum internal dimensions 20 x 20 cm
- 4) Chimney anti-explosion inspection door
- 5) External buffer wall
- 6) Chimney draught H shape

N.B. The above recommendations are approximate. The chimney installation must comply with local regulations.

**Attention:** the anti-wind device (3) **MUST** be positioned as shown in the drawings on the left. Otherwise, the heater may not work or may present serious combustion problems.

## TROUBLESHOOTING

PROBLEM	RESET BUTTON (13)		CAUSE	REMEDY
Motor does not start, no ignition	Off		-	Wrong setting of room thermostat or other control Check correct setting of heater control. If thermostat, make sure selected temperature is higher than room temperature
				Defective thermostat or other control Contact authorised Spitwater service agent
Fan does not start or stops during start-up or heating	Flashing orange		-	No electrical current Check mains Check proper positioning and functioning of switch, If incorrect contact authorised Spitwater service agent Contact authorised Spitwater service agent
				Possible electricity supply problem Contact licenced electrician
Fan stops during start-up or heating	Steady red	SELF-DIAGNOSIS LIGHT	Flashing orange	Presence of flame before transformer ignites Contact authorised Spitwater service agent
				Defective photocell Contact authorised Spitwater service agent
				Defective electrical motor Contact authorised Spitwater service agent
				Defective electrical motor bearings Contact authorised Spitwater service agent
				Burned out condenser Contact authorised Spitwater service agent
				Defective electric ignitor Contact authorised Spitwater service agent
				Defective flame control box Contact authorised Spitwater service agent
				Defective photocell Contact authorised Spitwater service agent
				Insufficient or no fuel at burner Contact authorised Spitwater service agent
				Defective solenoid Defective electric ignitor Contact authorised Spitwater service agent
	Flashing orange	Internal error of electronic device Contact authorised Spitwater service agent		
Fan starts and flame lights, generating fumes	Steady green		-	Insufficient combustion air Make sure air inlet and outlet are free Contact authorised Spitwater service agent
				Excess combustion air Contact authorised Spitwater service agent
				Fuel contaminated or contains water Contact authorised Spitwater service agent
				Air leaks in fuel circuit Check the seals on the ducts and the diesel filter
				Insufficient fuel at burner Contact authorised Spitwater service agent
				Excess fuel at burner Contact authorised Spitwater service agent
Heater does not stop	Steady green		-	Defective solenoid seal Contact authorised Spitwater service agent

If the heater is still not working properly, please contact your nearest authorized dealer.

